



HVAC - Actuator

HAL

HVA Actuator LIN1.3 (HAL)

| Product Name | HAL-480 | | |
|------------------------------|---------------|--------------|---------------------|
| Nominal Voltage | 13.5 V | | |
| Gear Ratio | 1/480 | | |
| Step Angle @ Output | 0.05625° | | |
| Nominal Speed | Speed Mode 0 | | |
| Detent Torque | >100 Ncm | | |
| LIN version | LIN 1.3 | | |
| Temp. Range | - 40 ~ + 85°C | | |
| Weight | <57 g | | |
| Speed Mode | Speed Mode 0 | Speed Mode 1 | Auto-Speed |
| Rotational Speed | 2.25 rpm | 2.81 rpm | ~ 7.5 rpm (no load) |
| Nominal Torque (23°C, 13.5V) | >50 Ncm | >50 Ncm | >40 Ncm |
| Noise at 100mm | <33 dB(A) | <33 dB(A) | <40 dB(A) |

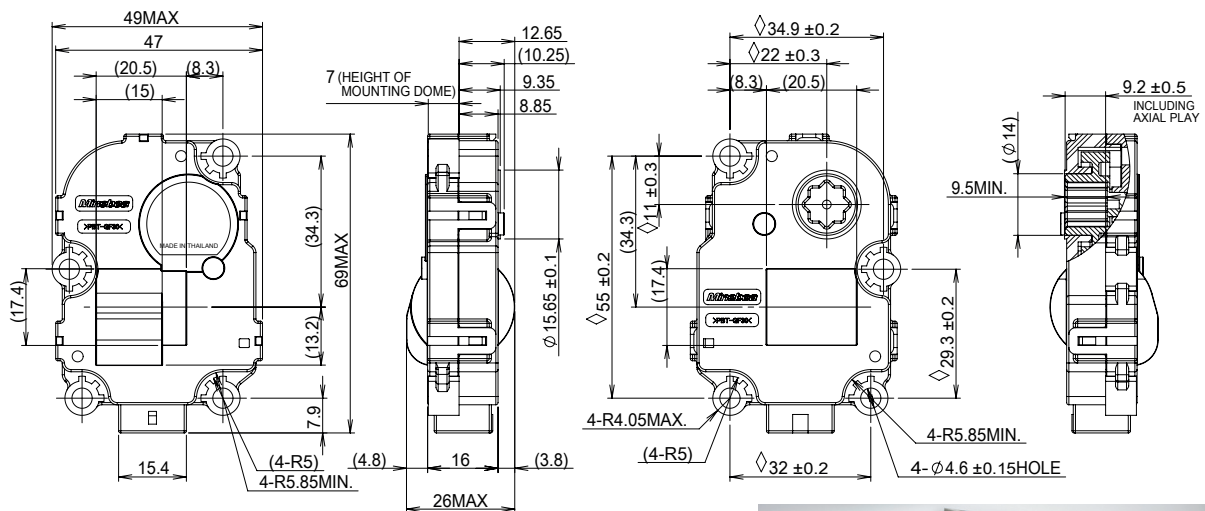

Features of HAL:

- Bipolar stepper motor
- Integrated electronics
- Selflocking gear
- Compact and lightweight
- High durability design

